

Direct Drive, Electric Flange Models

5/8" Hollow Shaft with NEMA 56C Mounting Flange
1750 RPM

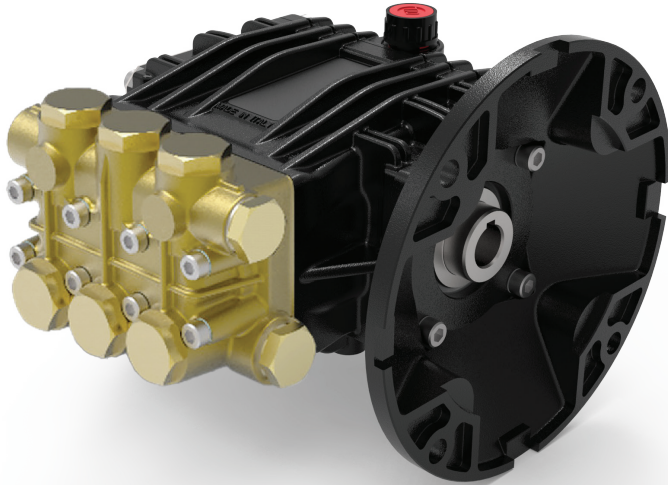

- Brass Manifold
- Heat Treated Crankshaft
- Stainless Steel Piston Guides
- High Strength Aluminum Alloy or Bronze Connecting Rods
- Industrial Quality Ball Bearings and Needle Bearings
- Solid Ceramic Plungers
- Stainless Steel Check Valves
- Heavy Duty Flat Base High Pressure Seals
- Dual Oil Sight Gauges
- 10.25 oz. Capacity Vented Oil Bath Crank Case
- 3/8" BSP-F Inlet. 3/8" BSP-F Outlet
- Max Fluid Temp, 160°F

PND Series 24mm Keyed Solid Shaft Plunger Pumps

PND Series standard duty plunger pumps include a wide range of models with flow rates from 0.5 to 4.0 GPM and pressures up to 2030 PSI.

Other drive options include 24mm solid shaft, gas engine flange, gas engine gear reduction and hydraulic motor flange.

Applications include general pressure cleaning, sewer jetting, vehicle wash equipment and fire fighting applications.

	Model	Flow		Pressure		Plunger Dia.	Crankshaft		Power	Seal Kit	Valve Kit	Wt.
		GPM	l/min	PSI	bar		Stroke	Code				
1750 RPM	PND 0.5/20 Z	0.5	2.0	2030	140	15mm	2.0mm	1	.75 EBHP	6061.07	6061.01	13 lbs
	PND 1.0/20 Z	1.0	3.8	2030	140	15mm	5.0mm	B	1.5 EBHP	6061.08	6061.01	13 lbs
	PND 1.5/20 Z	1.5	5.7	2030	140	15mm	7.5mm	H	2.0 EBHP	6061.07	6061.01	13 lbs
	PND 2.0/20 Z	2.0	7.6	2030	140	15mm	9.4mm	U	2.7 EBHP	6061.07	6061.01	13 lbs
	PND 3.0/15 ZA*	3.0	11.4	1450	100	15mm	12.5mm	S	3.0 EBHP	6061.07	6061.01	11 lbs
	PND 3.0/20 Z	3.0	11.4	2030	140	15mm	12.5mm	S	4.1 EBHP	6061.07	6061.01	13 lbs
	PND 3.5/20 Z	3.5	13.2	2030	140	18mm	10.5mm	O	4.7 EBHP	6061.08	6061.01	13 lbs
	PND 4.0/20 Z	4.0	15.0	2030	140	18mm	12.5mm	S	4.0 EBHP	6061.08	6061.01	13 lbs

NOTE: All pump models available with left-hand drive option. Add 'L' to model number when ordering (ex. PND 1.5/20 ZL)
*Aluminum Manifold

MAX FLOW
MAX PRESSURE
RATED PUMP SPEED
POWER REQUIREMENT
LUBRICATION

3.0 GPM / 11.4 L/MIN
2030 PSI / 140 BAR
1750 RPM
4.1 HP ELECTRIC
10.25 OZ UDOR LUBE

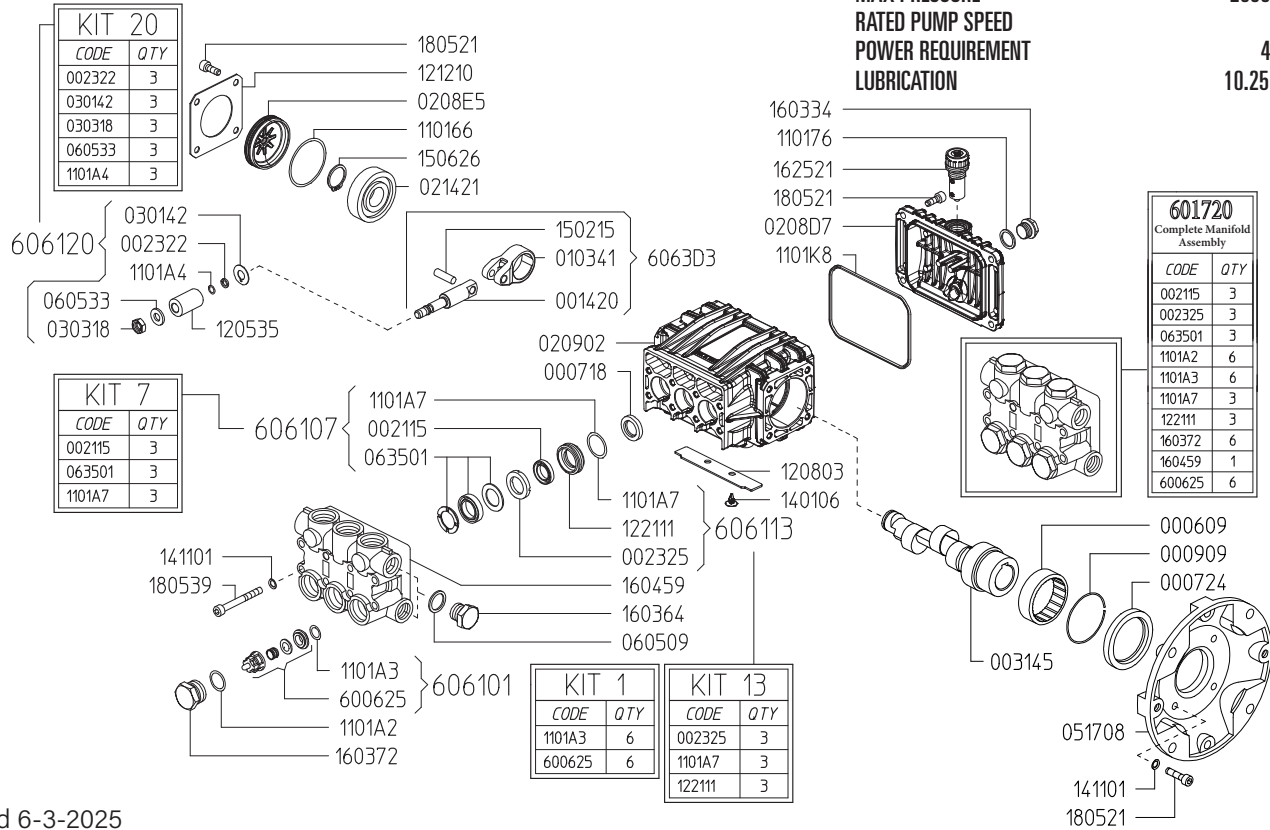

Revised 6-3-2025

Part #	Description	Qty	Part #	Description	Qty
0006.09	BUSHING D45X52X16 HK45-16	1	1101.K8	O-RING - BACK COVER	1
0007.18	OIL SEAL D15X24X4	3	1205.35	CERAMIC PLUNGER D15X30 "PN"	3
0007.24	OIL SEAL D40X52X7	1	1208.03	COVER - PN 2024	1
0009.09	ELASTIC RING D52X2.5	1	1212.10	METAL COVER "PN"	1
0014.20	PLUNGER GUIDE D15/18 "PN"	3	1221.11	LOW PRESS. SEAL RETAINER D15 ^{C E}	3
0021.15	WATER SEAL LP. D15 ^{B E}	3	1401.06	RIVED D4X10	2
0023.22	RING D6.3X9X1.3 2021 "PN/C/G" ^{C E}	3	1411.01	SERATED WASHER D6	12
0023.25	INTERMEDIATE RING D15 "PN"	3	1502.15	PIN D7X25.5	3
0031.45	HOLLOW SHAFT "PN" D5/8"	1	1506.26	SNAP RING D20	1
0103.41	CONNECTING ROD "PN/PS"	3	1603.34	PLUG G1/4	1
0208.D7	BACK COVER "PN"	1	1603.64	PLUG G3/8	1
0208.E5	COVER "PN"	1	1603.69	OIL PLUG G1/4+GASKET	1
0209.02	CRANKCASE "PN/PS"	1	1603.72	VALVE PLUG "PN"PISTON D15/18 ^{A E}	3
0214.21	BALL BEARING D20X52X15	1	1604.59	HEAD "PN" PISTON D15/18	1
0301.42	SLINGER RING "PN/PK/PKWT/PS" ^D	3	1625.21	OIL PLUG G3/8 "PN"	1
0303.18	NUT "PN/PK/PKWT/PS M8XH5 ^D	3	1805.21	ALLEN BOLT M6X22	12
0517.08	ENGINE FLANGE "PN" NEMA 56H	1	1805.39	ALLEN BOLT M6X60	8
0605.09	GASKET D17X23X1.5 (G3/8)	1	6006.25	VALVE ASSY "PN" W/O O-RING ^{A E}	6
0605.33	GASKET D8X14X2 ^D	3	6017.20	COMPLETE MANIFOLD ASSEMBLY	1
0635.01	HIGH PRESS. SEAL ASSY D15 ^{B E}	3	6061.01	KIT 1 - VALVE KIT "PN/PW"	1
1101.66	O-RING - BEARING COVER	1	6061.07	KIT 7 - WATER SEAL KIT D15 "PN/PK"	1
1101.76	O-RING - OIL PLUG	1	6061.13	KIT 13 - BRASS RING KIT D15 "PN"	1
1101.A2	O-RING - VALVE CAP ^E	6	6061.20	Kit 20 - PLUNGER KIT D15/18 "PN"	1
1101.A3	O-RING - VALVE ^{A E}	6			
1101.A4	O-RING - PLUNGER ^D	3			
1101.A7	O-RING - LP SEAL RETAINER ^{B C E}	3			

^A Parts in 6061.01 (Kit 1).
^B Parts in 6061.07 (Kit 7).
^C Parts in 6061.13 (Kit 13).
^D Parts in 6061.20 (Kit 20).
^E Parts in 6017.20 (Complete Manifold Assembly).

*Dimensional Drawings are
Shown in Millimeters.
To Convert to Inches,
Multiply Dimension x 0.03937*

PN SERIES PUMPS - 5/8" HOLLOW SHAFT w/ NEMA 56C FLANGE

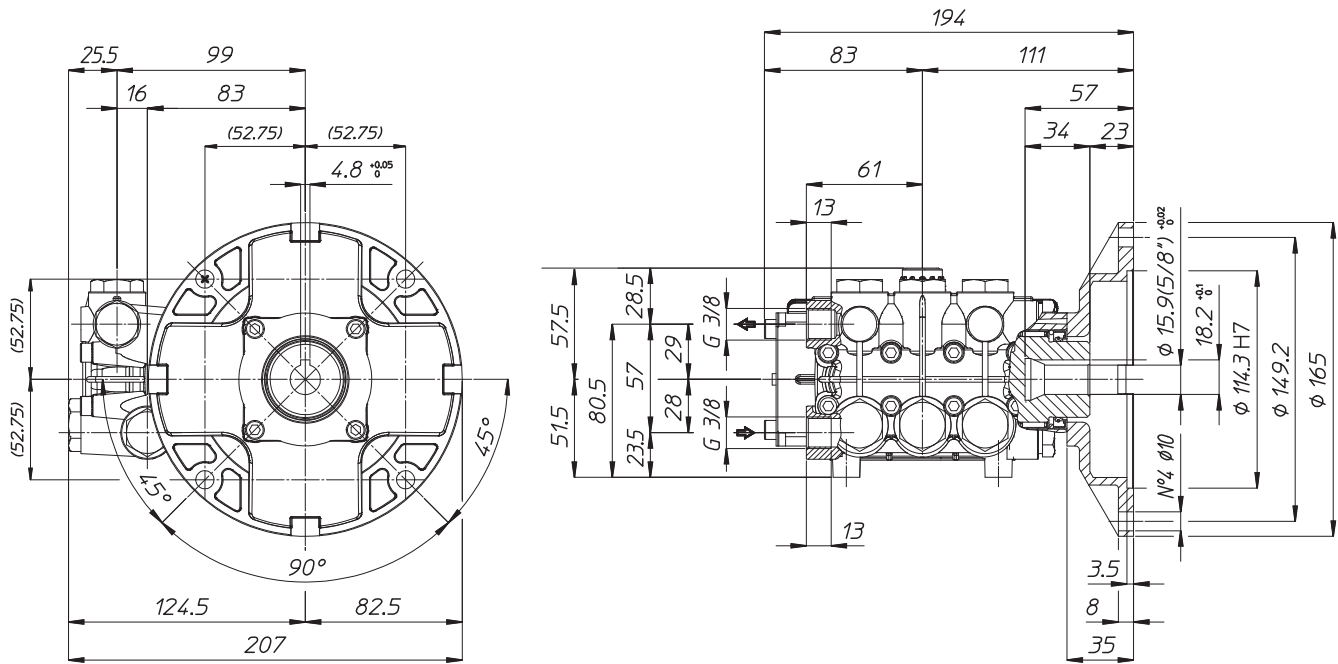

TORQUE SPECS

Ref.	Description	Ft./lb.	Nm	Loctite®
1	Head Bolts	8	11	-
2	Valve Caps	75	100	243
3	Inlet Cap	60	80	-
4	Outlet Cap	60	80	243
5	Bearing Flange Bolts	8	11	-
6	Rear Cover Bolts	8	11	-
7	Connecting Rod Bolts	-	-	-
8	Plunger Bolts	11	15	270
9	Valve Cover Bolts	-	-	-
10	Oil Drain Plug	6	8	-

